

SUPPORT PILLAR with OPTIONAL LOCKING SOLENOID FOR OCTAGONAL BOOM ARMS

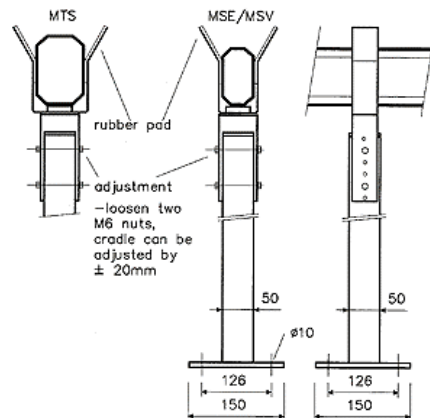

Options

Support post



The Magnetic support post is used with boom lengths which exceed 3.5m, to support the boom in the horizontal position.

The support post is constructed from rectangular steel tubing with RAL 2000 powder coating.

The cradle section at the top is designed to accommodate all Magnetic booms.

Page 2 of 5

PART NUMBER MAP5N-110 for a SUPPORT PILLAR
LIST PRICE (07/2009) = \$235.00

PART NUMBER MAP5H-110 for a SUPPORT PILLAR
with ELECTRO-MECHANICAL BOOM LOCK
LIST PRICE (07/2009) = \$430.00

USES REQUIRED:

PART NUMBER MMV1C-100 for a CONTROLLER for the
ELECTRO-MECHANICAL BOOM LOCK
LIST PRICE (07/2009) = \$290.00

NOTE: SUPPORT PILLAR COMES IN RAL2000 ORANGE ONLY

(ADDITIONAL CHARGE FOR ALL OTHER CUSTOM RAL COLORS)
LIST PRICE (07/2009) = \$142.00 for a CUSTOM RAL COLOR
ON THE SUPPORT PILLAR